

# Modular Work Centers

## Tear Cutter (D-9034)

CALSTONE INC - 020107

### Component Parts:

- 1 - Tear Cutter Channel (bar)
- 1 - Tear Cutter Angle Frame
- 2 - Tear Cutter Tube Mounts
- 2 - 1/4-20 x 3/4" Round Head Slotted Screws
- 4 - #10 x 5/8" Combination Screws

(Inspected by)

### Tear Cutter Assembly:

1. Place bar on floor with welded clip facing down.
2. Slide tube mounts in square slots of bar (one on each side) with holes facing out.
3. Place angle frame on top of tube mounts, matching holes and ensuring angle lip is on same side as welded clip.
4. Secure loosely with 3/4" screws supplied.
5. Place tear cutter assembly under front lip of front of table top, with angle lip facing out, and mark location of tube mount holes on underside of table top.
6. Remove and disassemble tear cutter.
7. Place tube mounts on underside of table, matching holes with markings and secure with four 5/8" screws supplied.
8. Reassemble bar and angle frame and secure tightly with 3/4" screws.
9. Feed paper through rear of Tear Cutter, between bar and angle frame.

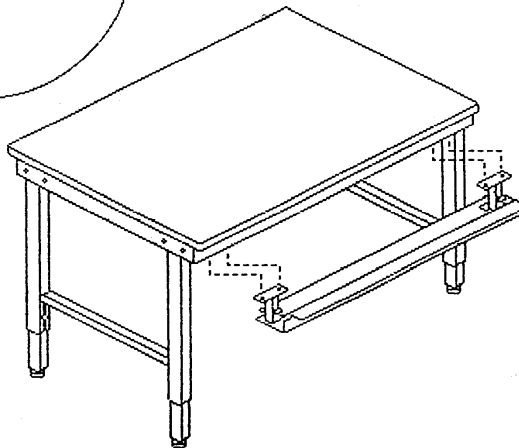
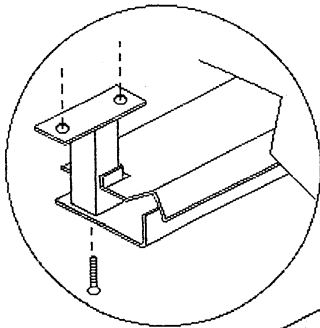

\*Do not discard packaging material until all contents are located\*